

**TOYOTA**



## **Toyota Approach to Environmental Improvement**

**Presented 10/20/23 (CARES NA 2023)**

---



Liesa Bednar  
Group Manager  
Toyota Paint PE

# Toyota Approach to Carbon Neutrality – Industry Background

All companies face competing interests when considering environmental projects:



Environmental Benefit and Global Citizenship



Customer Expectation



Operating Cost Benefit



Product / Equipment Expansion



Project Resources



Investment / ROI

**How to achieve Environmental benefit in the best way for society, customer, and company?**

# Toyota Approach to Carbon Neutrality – The Toyota Way

Toyota full company effort to sustainability.



**HEV**  
Less expensive than PHEV and BEV, capable of long-range driving.

**PHEV**  
Less expensive than BEV with comparable daily running costs, also capable of long-range driving.

**BEV**  
If using renewable energy, emits no CO2 when driving. Can be charged at home. Best for compact cars.

**FCEV**  
Long driving range with short refuel times, suitable for transporting heavy goods.

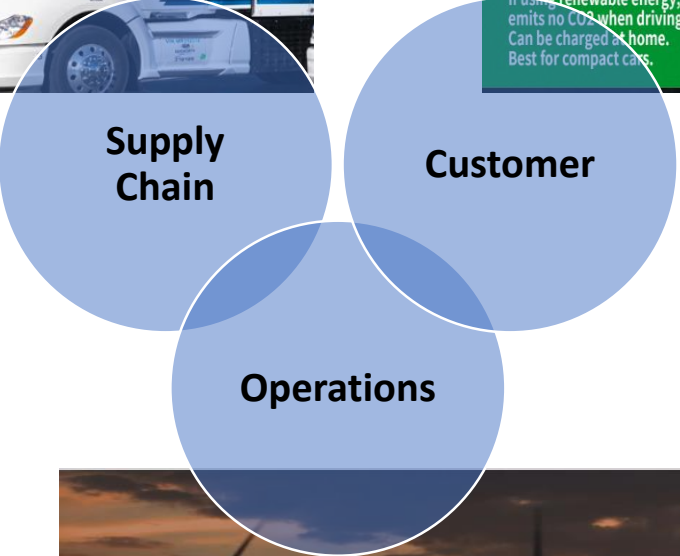

What approach does Toyota use for environmental improvement?

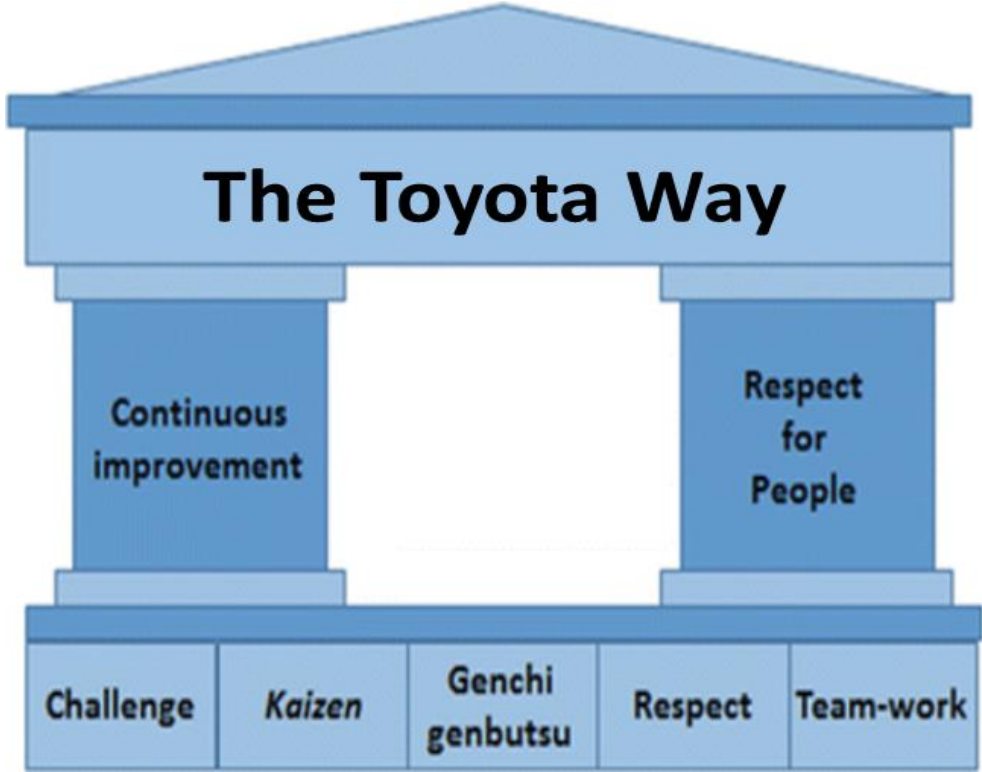
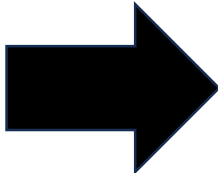

**The Toyota Way!**

# Toyota Approach to Carbon Neutrality – The Toyota Way (Challenge)

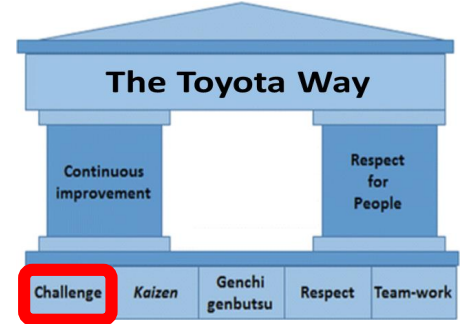

## Example – Projection of Carbon Emissions

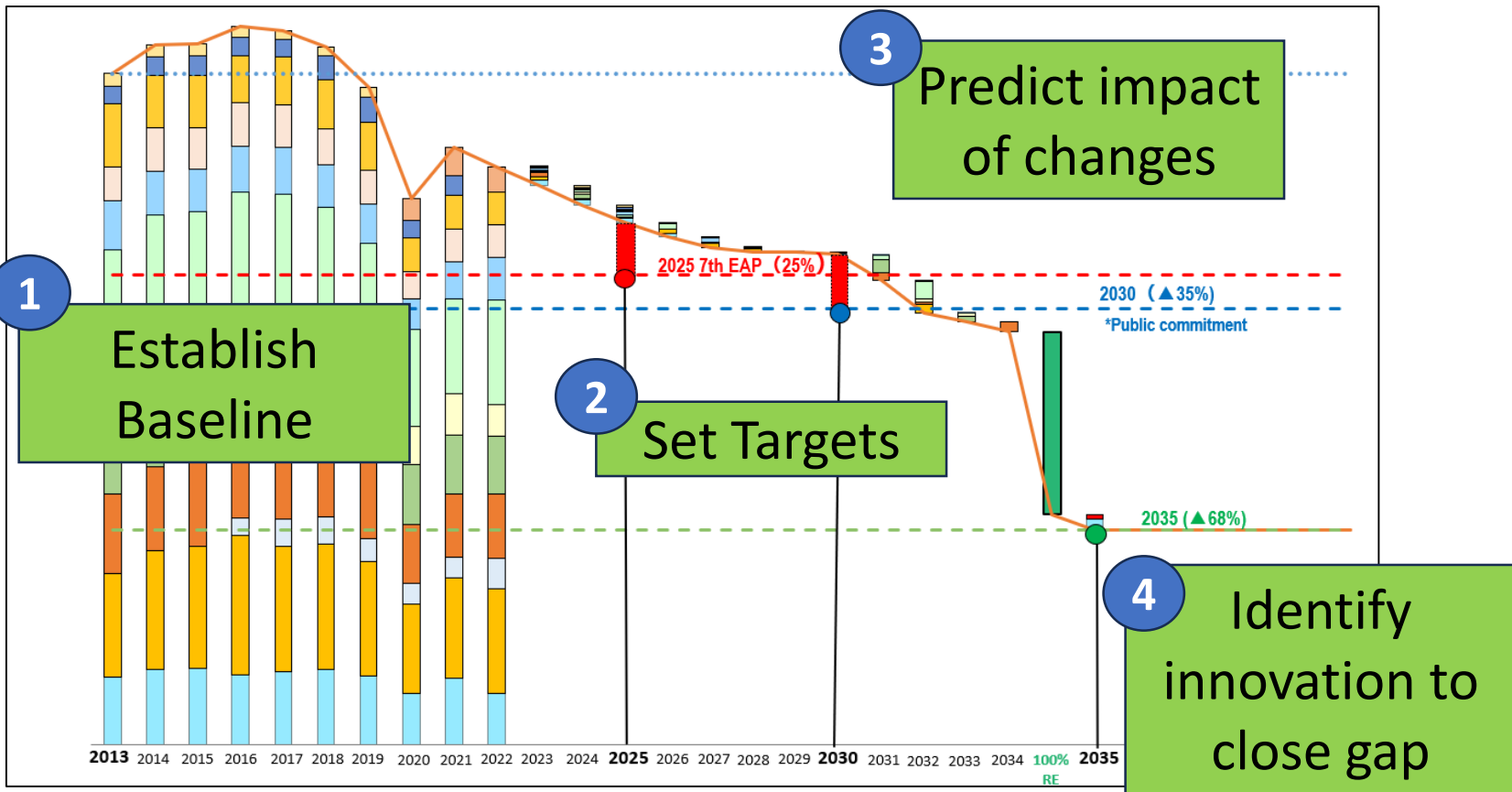

### Challenge

- Challenge the norm
- Set ambitious, measurable target
- **Measure progress to target, and update plan to achieve**

# Toyota Approach to Carbon Neutrality – The Toyota Way (Kaizen)

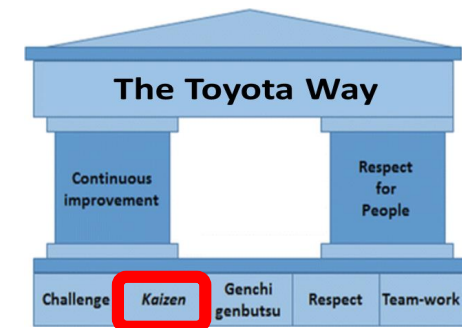

## Example – Paint booth innovation (Green Field)

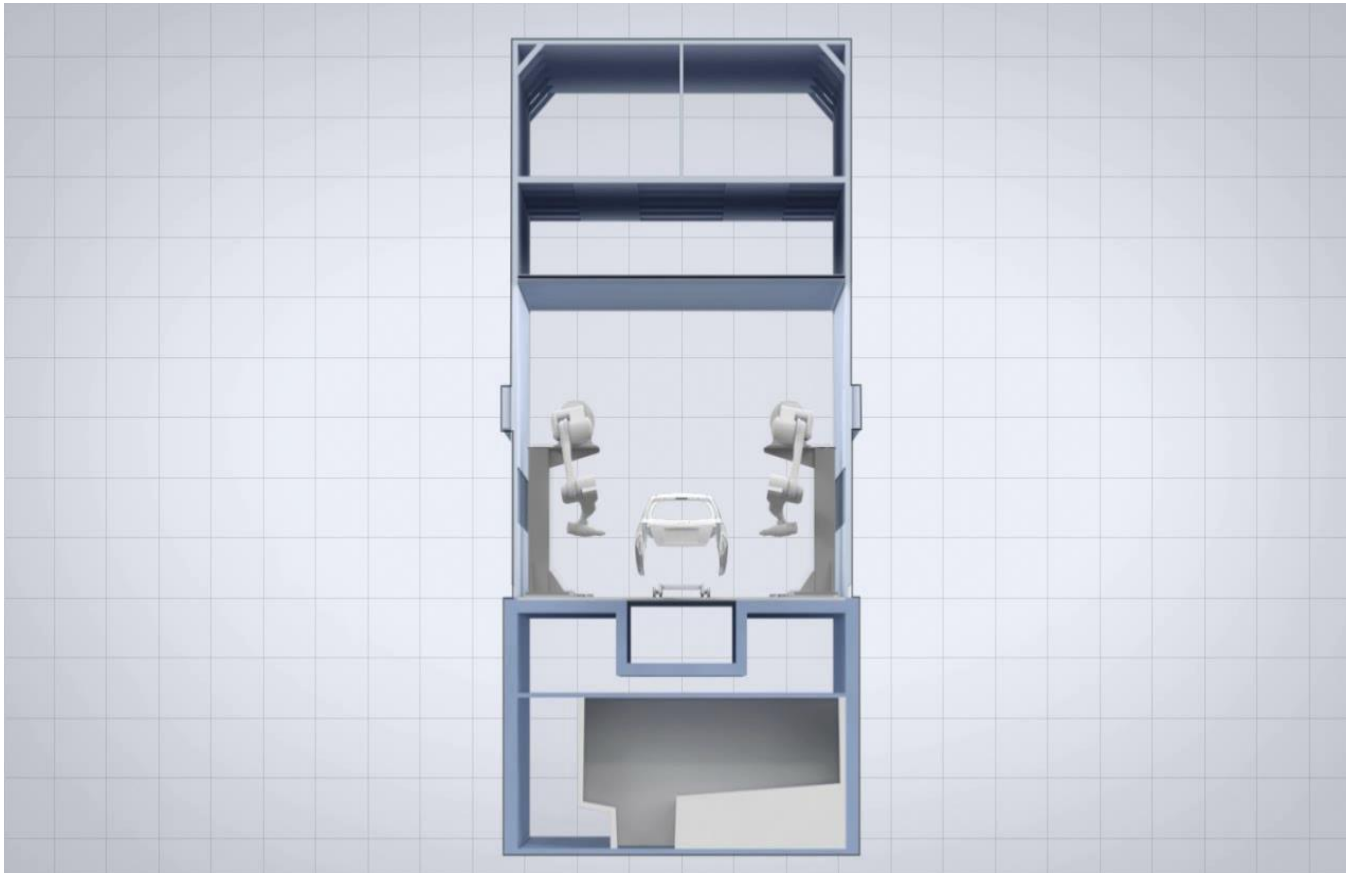

## Kaizen (Innovation)

- Innovative development from conventional Booth
  - Height : ▲40%
  - Length : ▲75%
  - Capacity : ▲90%
  - Reduce 70% CO2

# Toyota Approach to Carbon Neutrality – The Toyota Way (Kaizen)

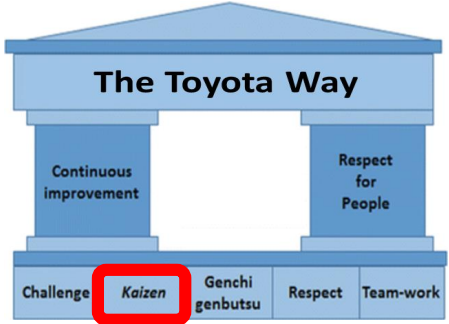

## Example – Paint booth improvement (Brown Field)

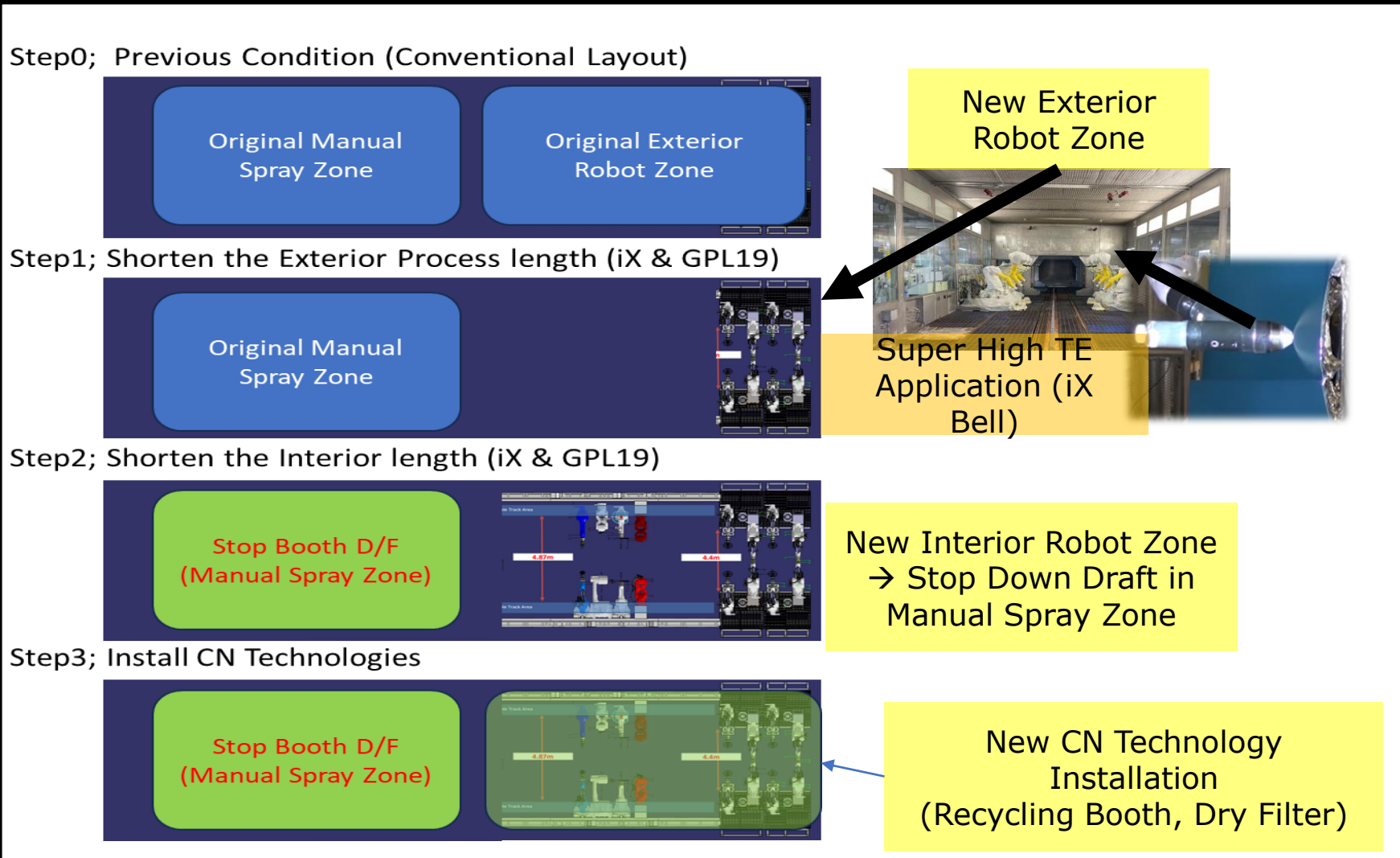

**Kaizen**  
**(Improvement)**

- Continuous improvement
- **Don't just "reduce impact" but "add value"**



# Toyota Approach to Carbon Neutrality – The Toyota Way (Genchi Genbutsu)

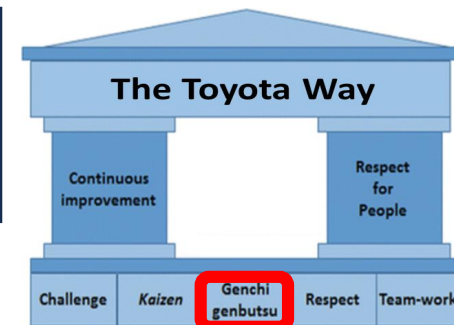

## Example – West Virginia Plant Solar Field

✓ Create solar field



↓  
How to care for area around solar field?

✗ Mow (equipment)

✗ Goats → Damage to solar panels!



✓ Adopt sheep → Perfect solution!

## Genchi Genbutsu

- “Go and See”
- **Understand the real problem in the real location**
- It’s ok to learn one step at a time

# Toyota Approach to Carbon Neutrality – The Toyota Way (Respect & Teamwork)

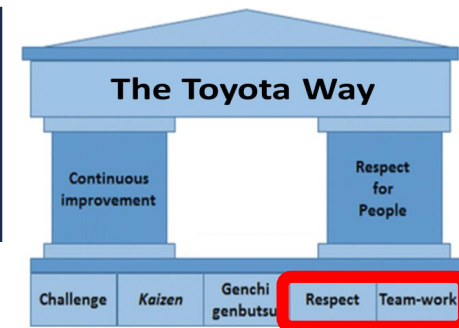

## Example – Cross Shop Group Sharepoint

PE Cross Department Carbon Neutrality Team

Carbon Neutrality Documents

Non-Production Energy Reduction Activities Documents

NAMC CO2 Roadmap

Assembly Body Casting Environmental MPIC Paint Plastics Powertrain Stamping VSI

Kaizen List Documents

Shop Contacts Contact List

## Respect & Teamwork

- **Work together across shops and business units – be intentional.**
- Create resources to allow easy sharing of information and best practices



# Toyota Approach to Carbon Neutrality – The Toyota Way!

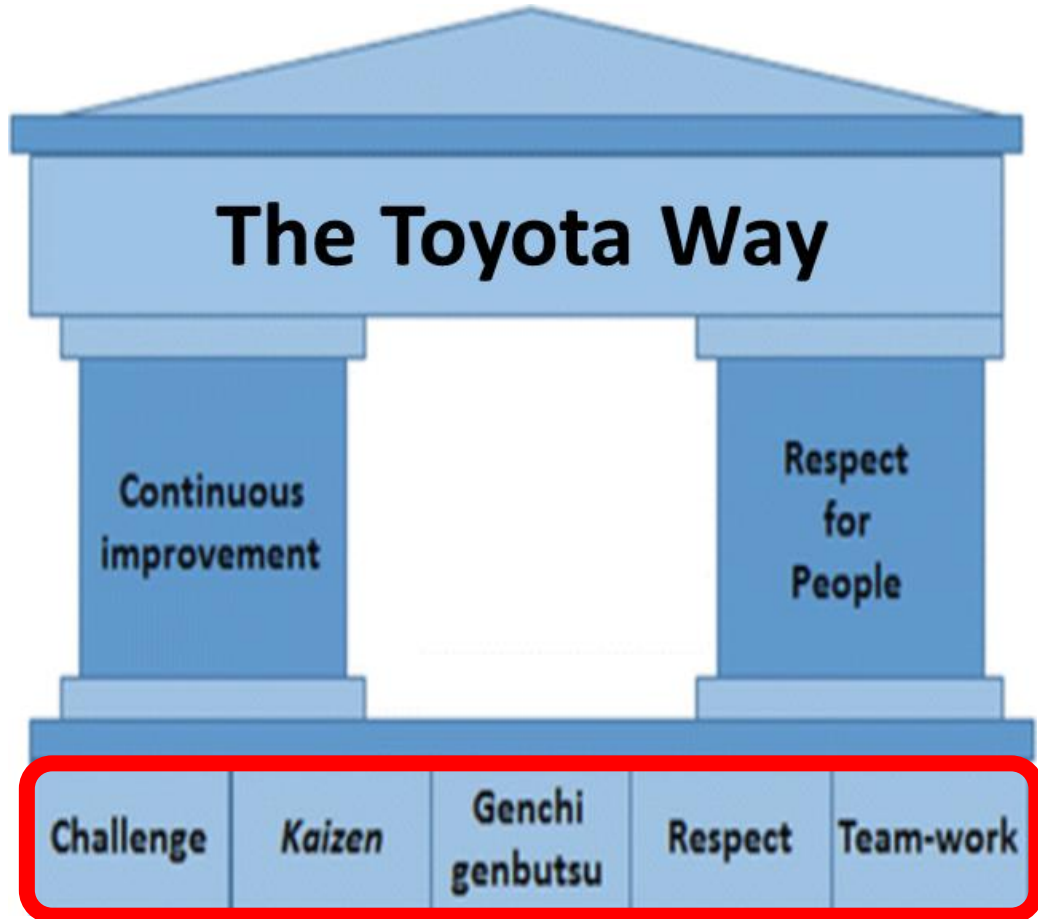

To achieve environmental improvement, stay true to core values—  
**The Toyota Way**

**“We can, We will!”**

# Toyota Approach to Carbon Neutrality – The Toyota Way!

**Thank you! Questions?**

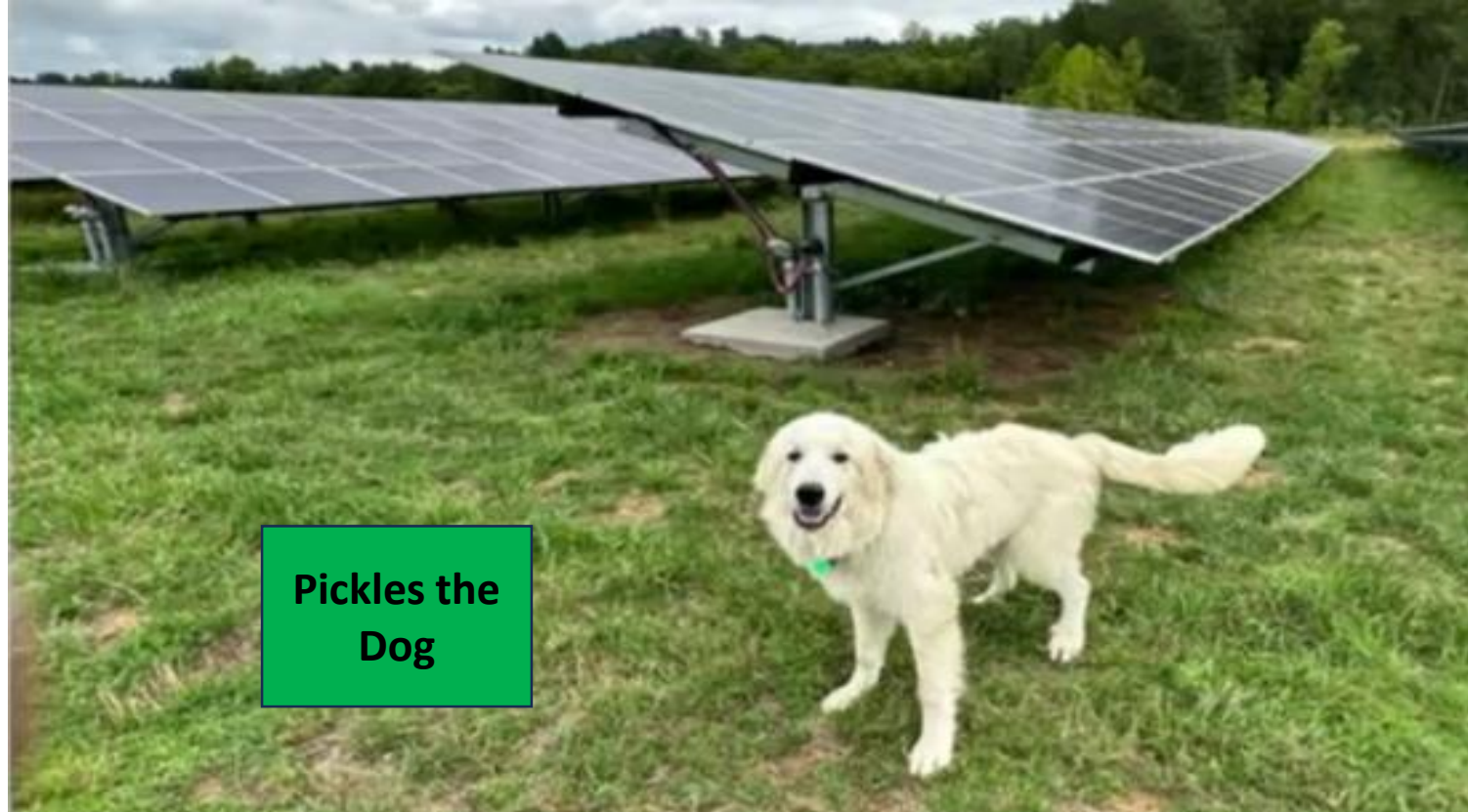

**Pickles the  
Dog**